

### Variload® Twist-Lock® Devices

In many large plants and laboratories the number of circuits of different ratings and frequency is greater than the number of blade configurations available in conventional wiring devices.

Prior to NEMA configuration standardization the solution was “Variload® Twist-Lock®” devices with four non-interchangeable center pin and slot configurations that can be assigned within the same premises to circuits of same voltage, frequency and supply (AC or DC), in accordance with NEC® 406.4(F) and 406.8 and with CE Code, Part I, Rule 26-700(3).

### 30A, 250V DC Max. and 600V AC Max. 50 - 400Hz

Center Pin Configuration	Plugs	Flanged Inlets	Connector Bodies	Receptacles
	<b>HBL45115</b>	–	<b>HBL45135</b>	<b>HBL45105</b>
	<b>HBL45215</b>	–	<b>HBL45235</b>	<b>HBL45205</b>
	<b>HBL45315</b>	–	<b>HBL45335</b>	<b>HBL45305</b>

### 20A 3ØY, 120/208V AC Only, 400Hz

Center Pin Configuration	Plugs	Flanged Inlets	Connector Bodies	Receptacles
	<b>HBL45915†</b>	<b>HBL45985CL†</b>	<b>HBL45935†</b>	<b>HBL45905†</b>

Note: †UL Listed only.

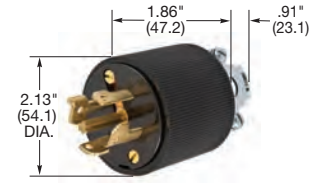

**HBL45315**

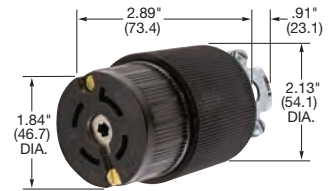

**HBL45335**

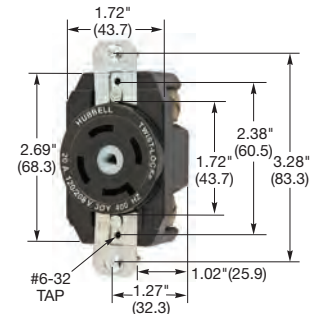

**HBL45305**

### Receptacle Wallplates

Description	Catalog Number
Single Receptacle with Face Dia. 1.74" (44.2) Stainless steel 302/304, .035 in. (0.9), horizontal brushed finish.	<b>SS725</b>



**SS725**

**IP55\***  
SUITABILITY

### Weatherproof Boots

Description	Catalog Number
Seal-Tite® black elastomer for Variload® plugs.	<b>HBL6027**</b>
Seal-Tite® black elastomer for Variload® connector bodies.	<b>HBL6028**</b>

Note: \*When installed and used properly with plug and connector body combinations.

\*\* Weatherproof boots not UL Listed, nor CSA Certified.



**HBL6027**



**HBL6028**

**CAUTION: To avoid electrical shock, review premises carefully and do not use if slot or blade configuration (design) is already in a circuit having a rating differing from the rating of this device.**

Dimensions in Inches (mm)